

INSTALLATION INSTRUCTIONS

ZETOR RANGE I SUPER TURBO

7321 – 7341

Hammond Air Conditioning Ltd.
Ingersoll, Ont., Canada
1-800-267-2665
1-888-267-3745 (Fax)

CONDENSER:

The condenser is mounted within a bracket assembly designed to allow it to be slid into and out of the condenser cradle for ease of cleaning the condenser and radiator.

1. Remove the condenser from its cradle and remove the existing fasteners from the two lower positions on either side of the radiator frame. Discard the removed hardware.
2. Mount the condenser frame in front of the radiator using the hardware from the installation kit. Make sure to maintain the same orientation as set up when shipped.
3. The condenser slides into place in the cradle and is secured with the wing bolt in the hardware package.

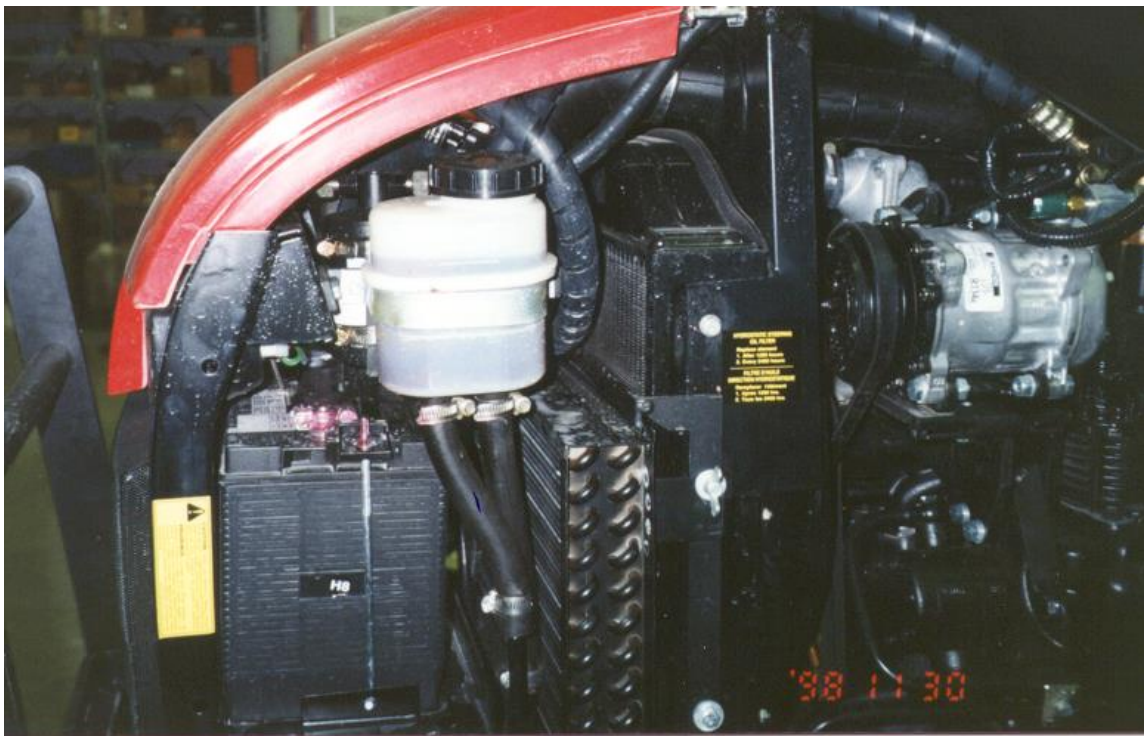

Condenser installed with hoses. Note orientation on tractor and location of wing bolt.

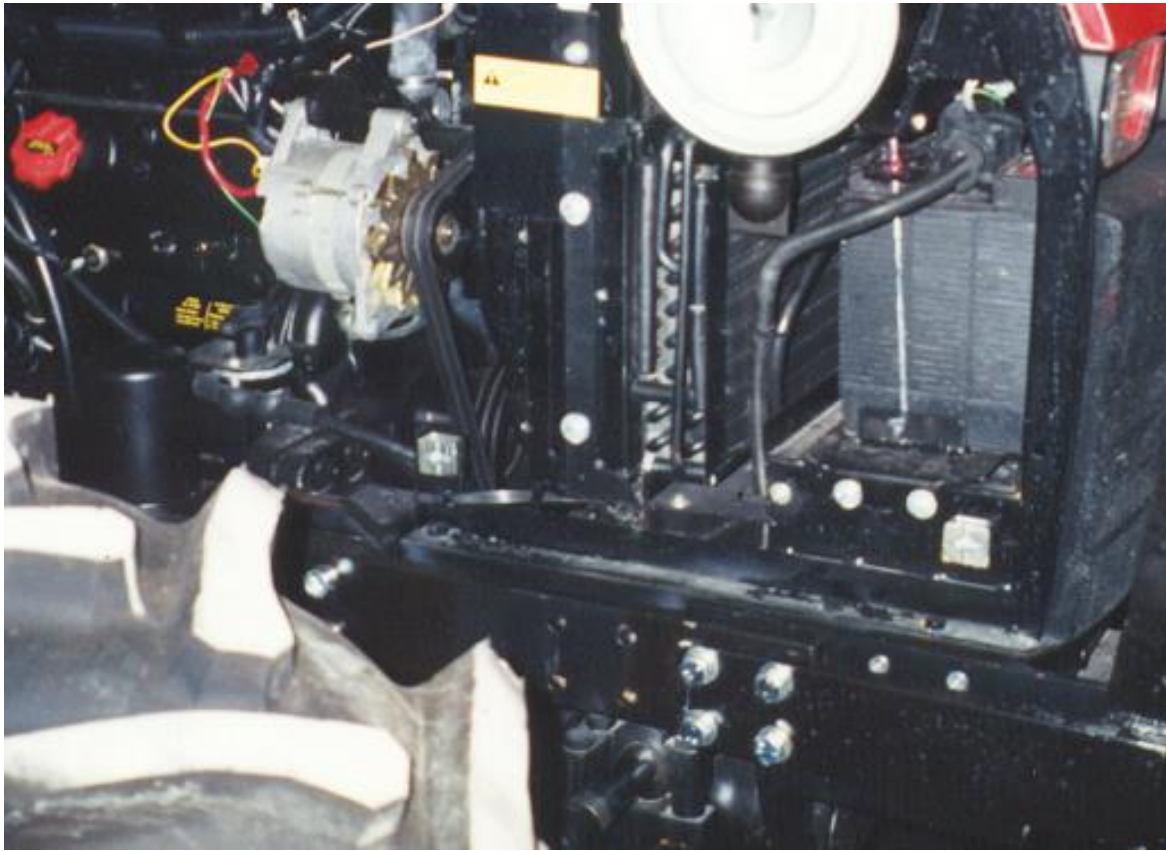

Right side of condenser with mounting hardware for frame.

COMPRESSOR:

The compressor is mounted on the fabricated mount assembly on the upper left of the engine.

1. Raise the hood and either move or remove any implements that may restrict access to the compressor mount area.
2. Prior to installing the compressor mount the turbocharger oil line must be replaced with the oil resistant line supplied.
3. Cut the upper and lower portions of the pipe as shown in the pictures and replace on the engine.

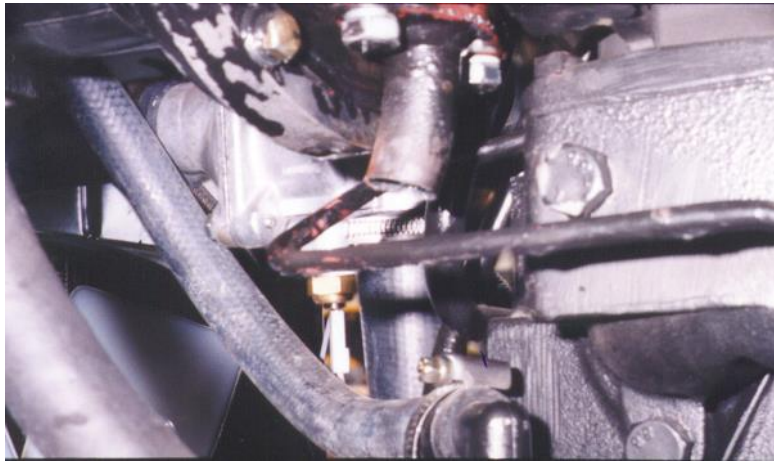

Top turbo oil port tube cut to length.

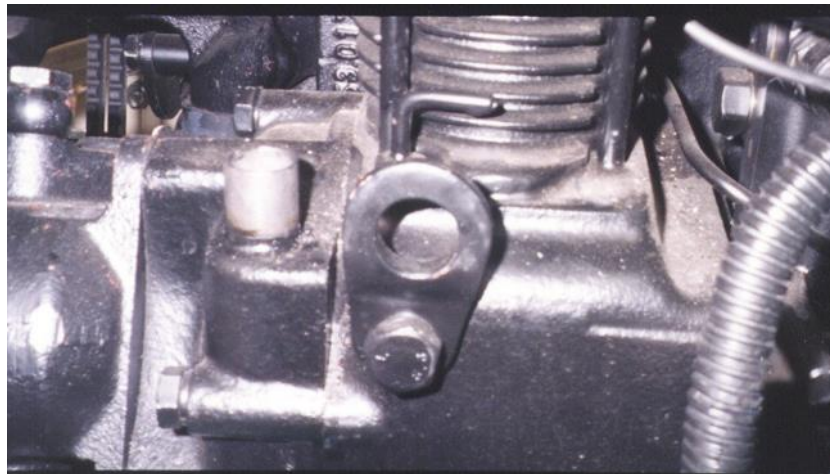

Bottom turbo oil port tube cut to length.

4. Install the new oil resistant line to the upper and lower ports with the gear clamps as shown.

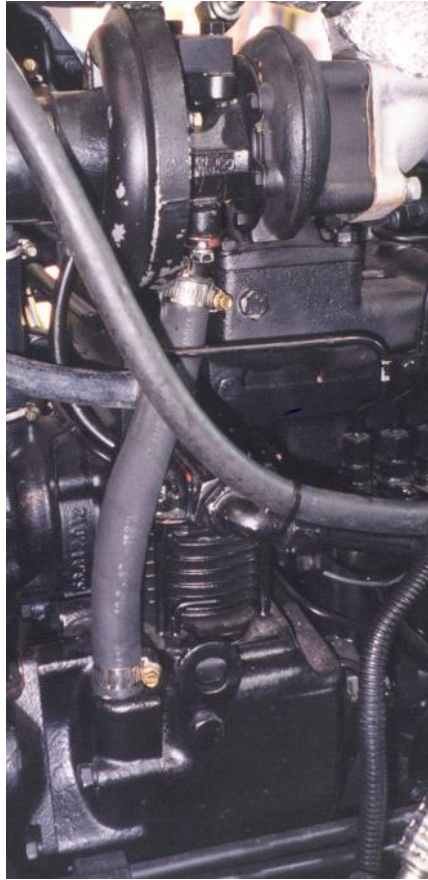

Replacement turbo oil line in place.

5. The small mounting lug extending down at the front of the compressor mount base picks up the bolt on the top of the fuel pump housing. At the back of the compressor mount the two bolts on the face of the water pump housing are picked up. At this time remove these three bolts and set aside.



Front bolt on compressor mount.

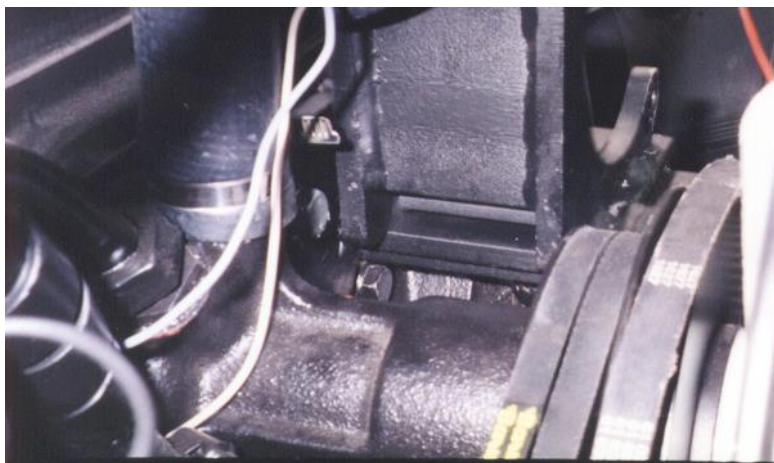

Rear bolt point (top one) on compressor mount. There is a second bolt below and not shown.

6. Secure the compressor mount base into position using the hardware in the kit. Secure the adjuster ear assembly of the compressor mount to the mount base with the two bolts supplied.
7. Put the belt in place around the fan hub pulley (the open one). Mount the compressor to the compressor mount as shown in the pictures and tighten the belt.

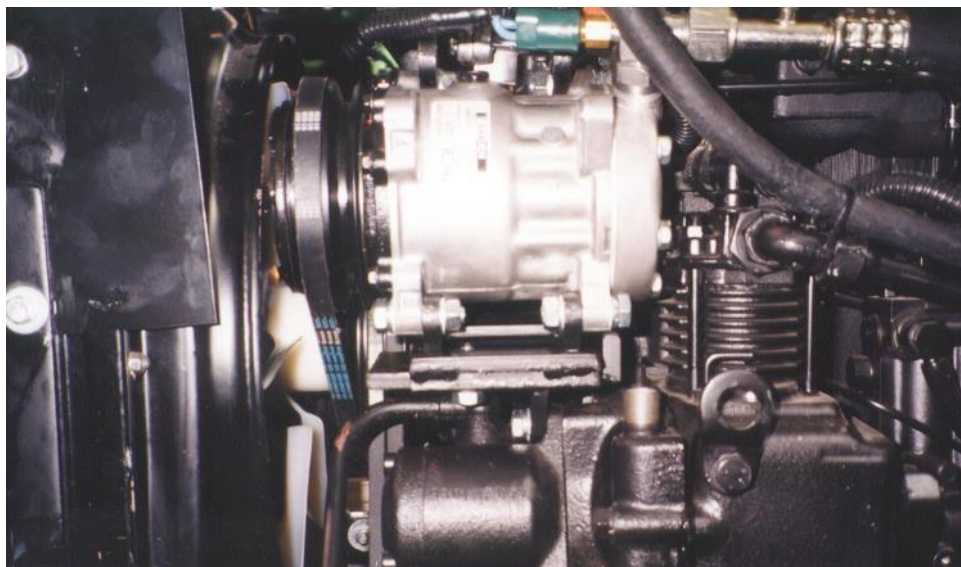

Compressor mounted in place with belt on.

EVAPORATOR:

The evaporator assembly is designed to mount in the roofline of the tractor and reuse the original heater core.

1. Raise the roof of the tractor and open up the interior to access the heater area.
2. Remove the existing heater assembly and the gray plastic box. Make sure all the plastic is removed from the headliner. This may take some effort to remove all the plastic from the headliner as it is glued on.
3. While the headliner is open cut the seven (two optional for additional defrost function) 2 ½" holes for the air distribution louvers. Five are set in the middle of the headliner with the other two (optional) set off to the sides at the windshield for defrost functions.
4. At this time it is also best to set up the drain lines through the headliner. Set them up as shown in the pictures.

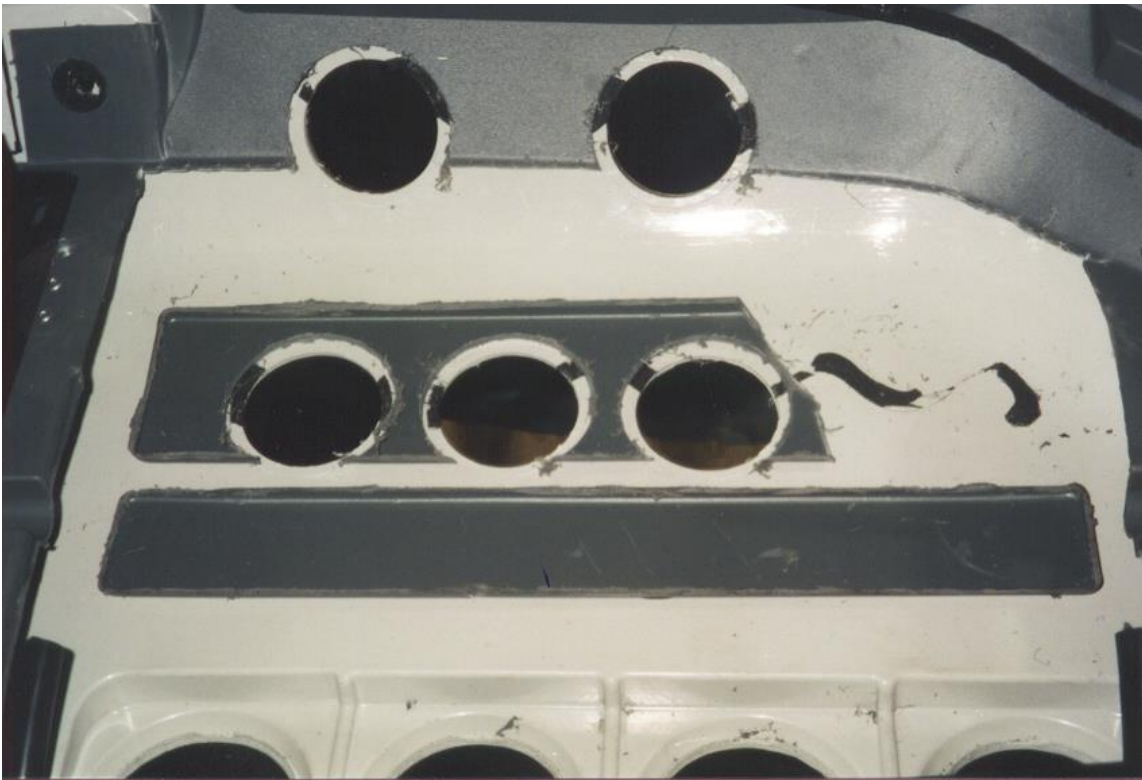

Hole cutouts for air distribution louvers facing operator.



Louver arrangement with defrost louvers (optional) left and right at the windshield.

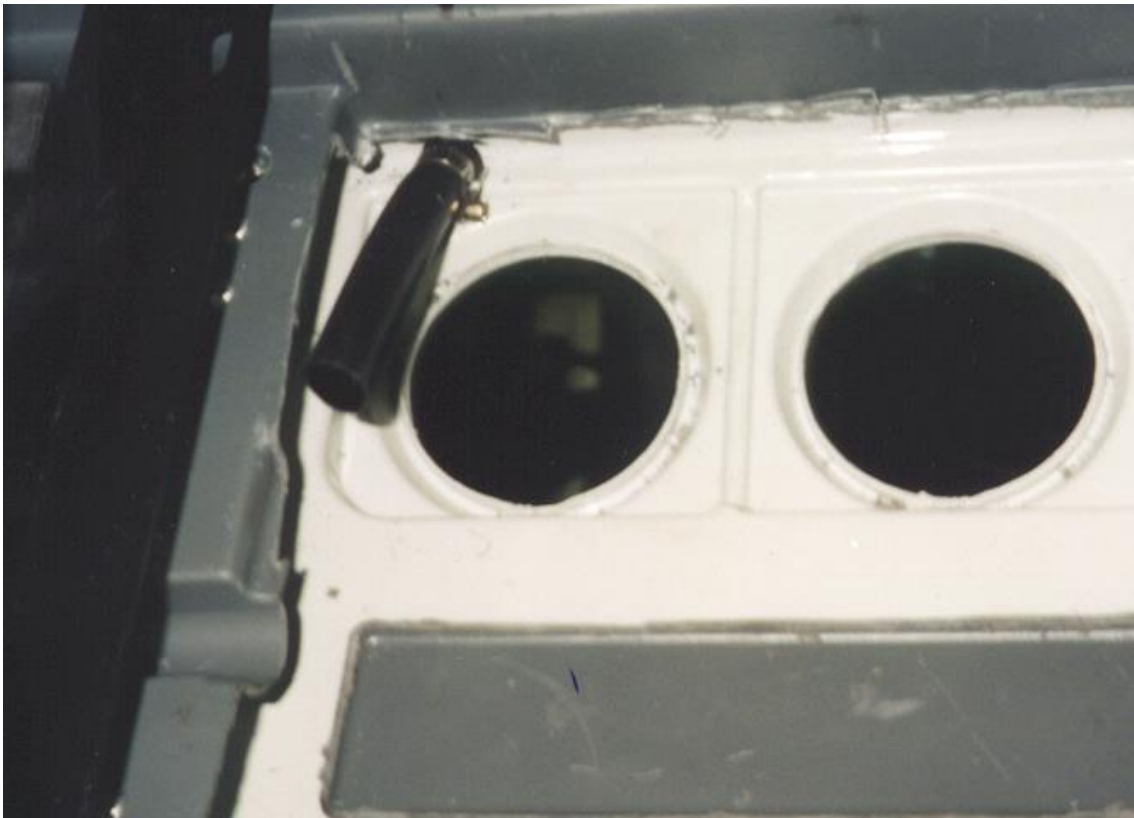

Drain tube on top side of headliner showing location for set-up.



Drain tubes running along underside of headliner.

5. (OPTIONAL) There are four recirculation louvers that can be installed at the rear of the cab for increased cab air recirculation. They are cut in and installed as shown in the picture.



Rear recirculation louvers in place.

6. The OEM heater coil and control assembly is removed from the factory heater box and installed in the heat/AC assembly supplied. The coil is slid into position with the control valve still attached.
7. Remove the factory heater control cable and replace with the one supplied in the kit. The control cable for outside air control is removed from the control head and discarded.
8. The entire assembly is mounted onto the original mounting brackets in the roofline of the cab and bolted down as shown below.

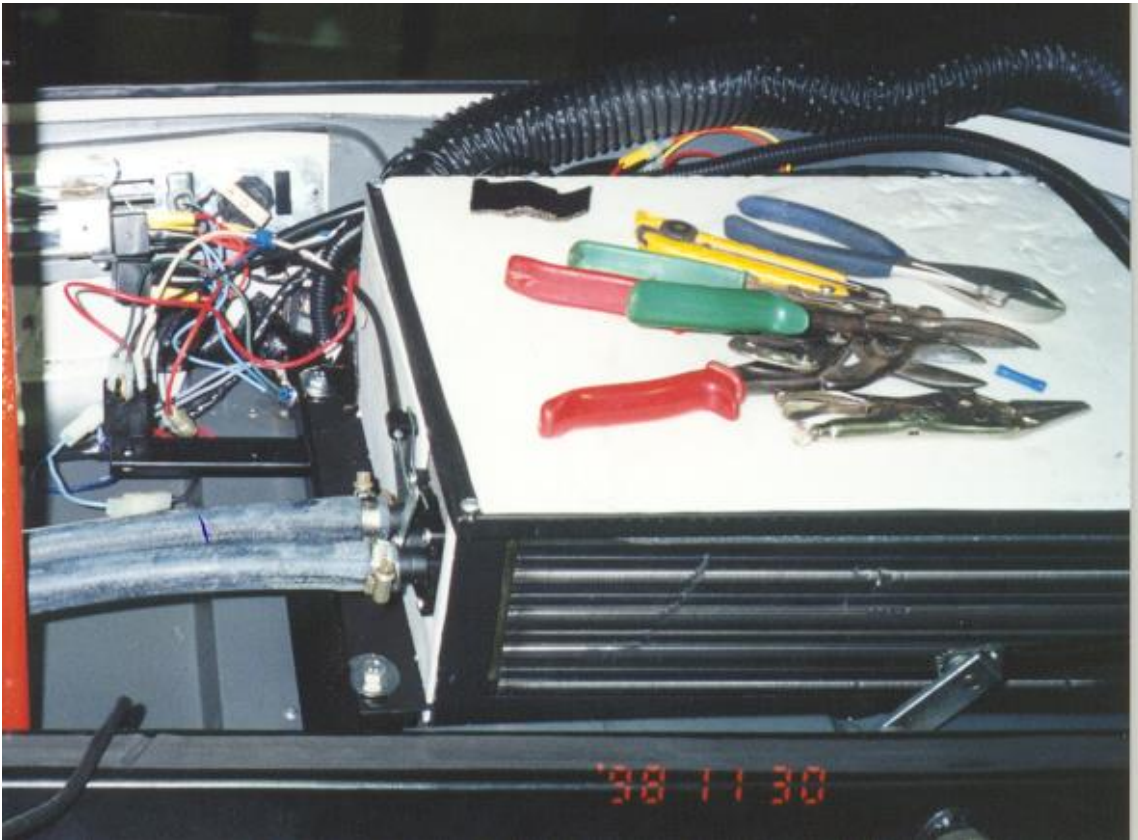

Heater side of the evaporator box assembly mounted in place with the new control cable.

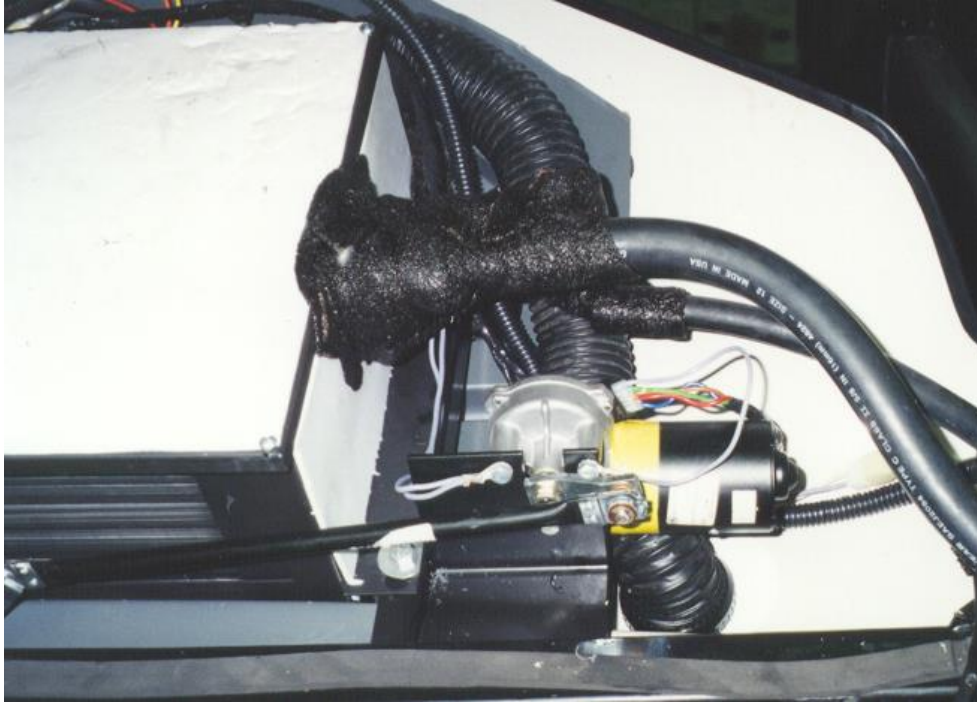

The air conditioning side of the evaporator box assembly with lines in place.

NOTE: the optional defrost line in place as shown here.

9. The optional defrost arrangement is supplied standard in Canada and as requested elsewhere. The louvers are cut into the headliner as shown in the pictures above. They have a 2 ½” ball louver with a 2” hose adapter for each side included. The 2” flex duct is also included in the kit.
10. For the right defrost louver cut a 3” hole in the dark gray ‘inner’ headliner material and then a 2 ½” hole in the outer headliner. On the left side cut the 2 ½” hole for the louver as shown.
11. Route the thermostat assembly to the face of the headliner and install in a convenient location near the existing control switches. The current location is on the panel directly under the factory blower switch.



12. Connect the drain tubes up to the evaporator drains. Drill and tap the columns for 1/8"NPT and thread in the 90o street elbow supplied (there is a nipple inserted into the female end of the street elbow for the drain tube to attach to). Use thread tape or sealer to waterproof the joint.

RECEIVER DRIER:

The receiver drier is mounted in the front of the tractor at the power steering reservoir.

1. Remove the two bolts from the power steering reservoir and retain.
2. Place the drier bracket into place with the long arm of the bracket pointing down. Line the two holes up with the mounting location bolt holes for the power steering reservoir. Using the original hardware bolt into place.
3. Secure the drier into place with the two #48 gear clamps and line up to orient the inlet fitting to take the hose from the condenser.

*****NOTE*** On later manufactured tractors the power steering fluid reservoir tank used is different and some modification to the bracket may be required on site.**

ELECTRICAL:

The electrical requirement for the air conditioning system is for a 12 volt supply with a draw of approximately 5 amps.

1. A 12ga red power wire is taken directly off the alternator and run up to the cab. A 10 amp fuse in an ATO type holder is spliced into the line not more than 24" (60 cm) from the supply source.
2. In the cab a relay is installed on the bracket on the right side of the evaporator box. The 12 ga red supply wire is connected to post #30 on the relay.
3. A wire is spliced onto the low speed power wire on the blower switch (it should be 'live' anytime the blower is on) and connected to terminal #85 on the relay. Ground terminal #86 to a cab ground and test the relay for operation.
4. From the relay output terminal (#87) run a 14ga black wire to the thermostat. From the thermostat connect to the black 14ga wire running down the column. Connect this wire to one of the pressure switches. Connect the remaining pressure switch in series and then to the compressor.
5. Use the wiring diagram provided below as a reference.

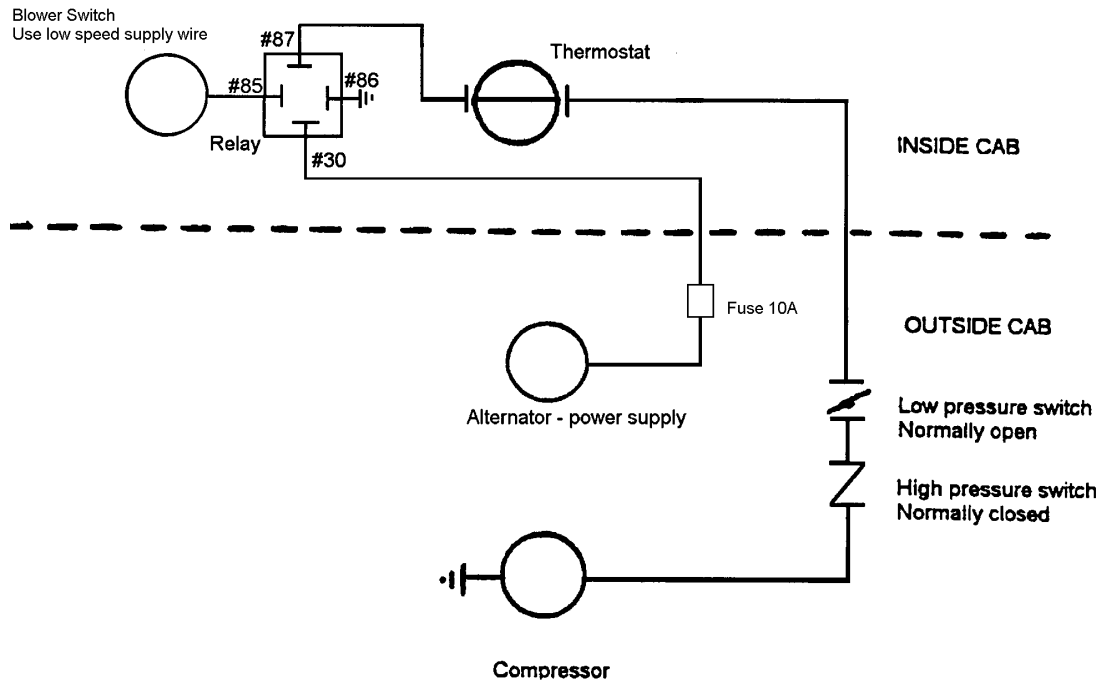

HOSE ROUTING:

The hoses are all pre-crimped with the fittings installed on both ends and pressure tested prior to being included in the kit. Where necessary refer to the pictures in the other parts of the installation instructions for routings.

13/32" Compressor to Condenser:

1. The hose is pre-assembled with all fittings in place and oriented correctly. With the 1/2" spiral cut hosewrap wrap the length of the hose where it may chafe or wear before installing.
2. The 90o fitting with the charging port is connected to the rotolock fitting on the compressor with the high pressure switch (black leads). Check the pictures for proper orientation of the fitting.
3. Route the hose forward over the radiator and loop around to leave sufficient hose to remove the condenser for cleaning. The hose is specifically cut to the correct length for this purpose and does not need to be shortened in length.
4. Secure as required with clamps or cable ties.
5. Connect the condenser end hose fitting to the appropriate condenser fitting and tighten securely.

5/16" Condenser to Receiver Drier:

1. The shorter of the 5/16" hoses is designed to run from the outlet fitting on the condenser to the receiver drier.
2. Connect the straight fitting to the condenser and run the hose around so that the condenser can be easily removed and the hose will not bind on any obstructions.
3. The 90o fitting connects to the 'INLET' fitting on the receiver drier. Secure with the 'O' ring.
4. Check to make sure that the condenser can be slid out from in front of the radiator without any problems. If necessary re-route the hoses to allow for this.

5/16" Receiver Drier to Evaporator:

1. The hose from the drier to the evaporator must be run from the top of the cab down. Connect the 90o fitting to the expansion valve and then the hose must be run down the column. The 5/16" hose **must** be run down with the clutch wire.
2. Run the hose from the base of the column forward and feed through to in front of the tractor following the routing shown in the photographs.
3. Connect to the 'OUTLET' fitting on the receiver drier.

5/8" Evaporator to Compressor:

1. After connecting the fitting at the short end of the hose to the evaporator outlet fitting and running the hose down the column with the 5/16" hose, the 5/8" hose is routed to the compressor along with the clutch wire.
2. Connect the straight fitting with the 134a charging port to the suction side rotolock on the compressor (see compressor installation pictures) and secure firmly.

NOTES:

1. **All fittings are pre-crimped and tested for leaks. If you suspect a leak in a fitting contact Hammond Air Conditioning Ltd.**
2. **Hosewrap and cable ties are included in the kit for use protecting the hoses from damage. Hoses wearing through are not warrantable as they are a preventable installation related failure.**
3. **At the top of the column the 90o splices should be secured together and to the frame of the cab. The 5/8" fitting and hose should be wrapped in insulation tape as shown to prevent condensation from forming. Additionally – the cab roof immediately above the point the hoses/fittings exit the top of the column will need to have the inside modified to allow for the roof to close. Use a 2" hole saw to notch out the inside of the roof to fit over the hoses and fittings in the corner.**
4. **Use the O ring seals provided in the kit on all fittings and lubricate with refrigerant oil to ensure a correct seal.**
5. **Do not re-assemble the tractor until the air conditioning system has been tested for mechanical and electrical operation and leak tested.**

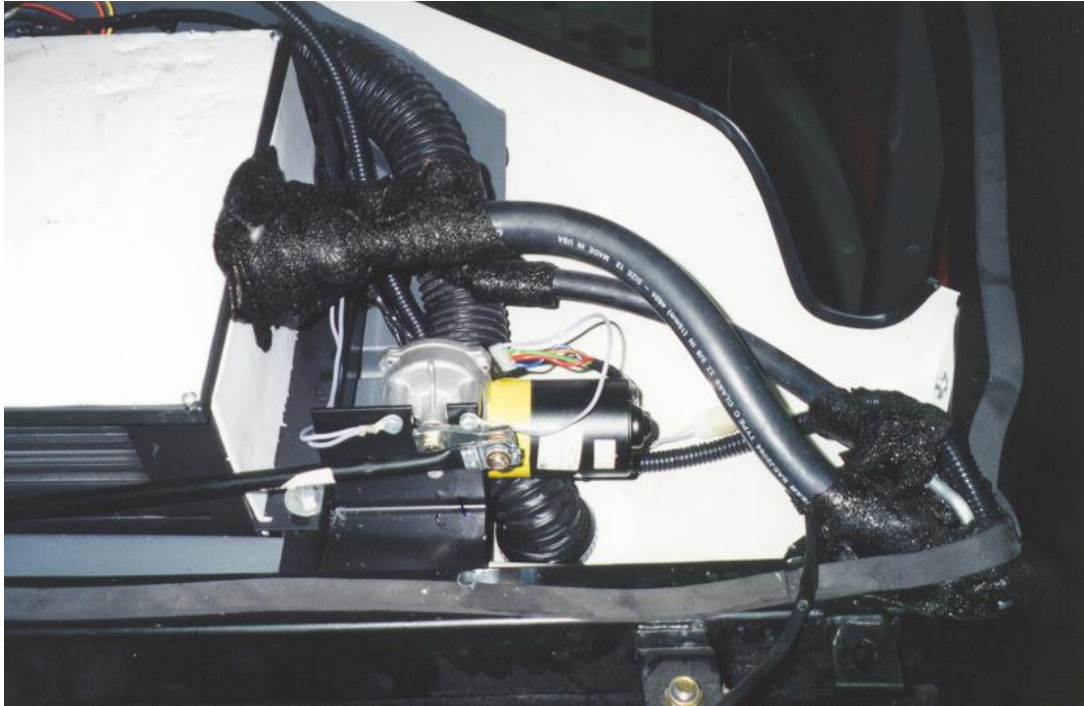

Hoses at evaporator to top of column. Insulated with tar tape.

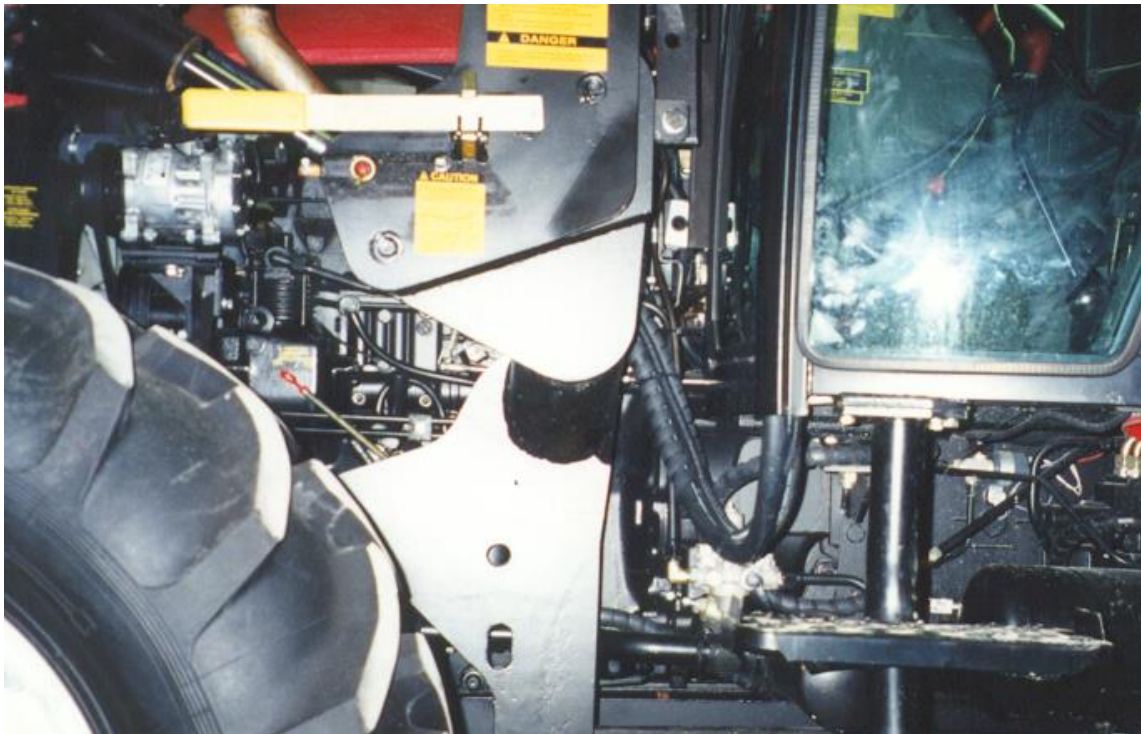

Hoses at base of column running up to the compressor.



Hoses and fittings at compressor.

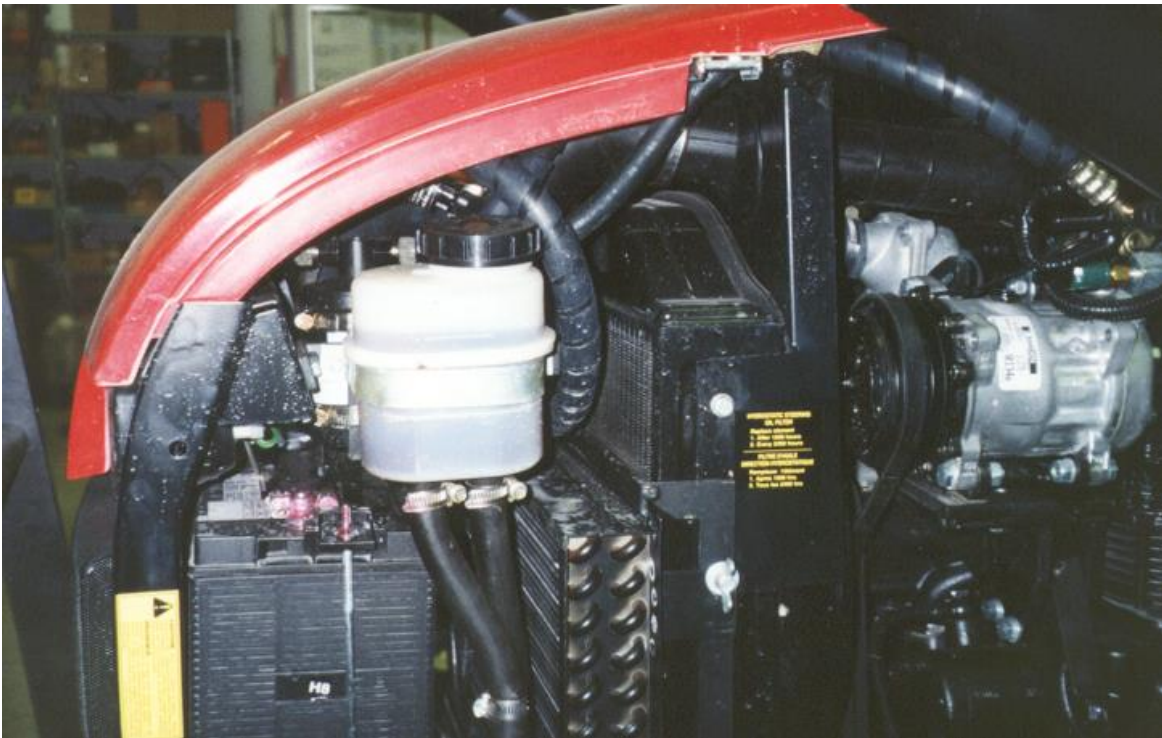

Hoses at the front of tractor to condenser and drier.

Refrigerant Flow Pattern in a Standard Air Conditioning System

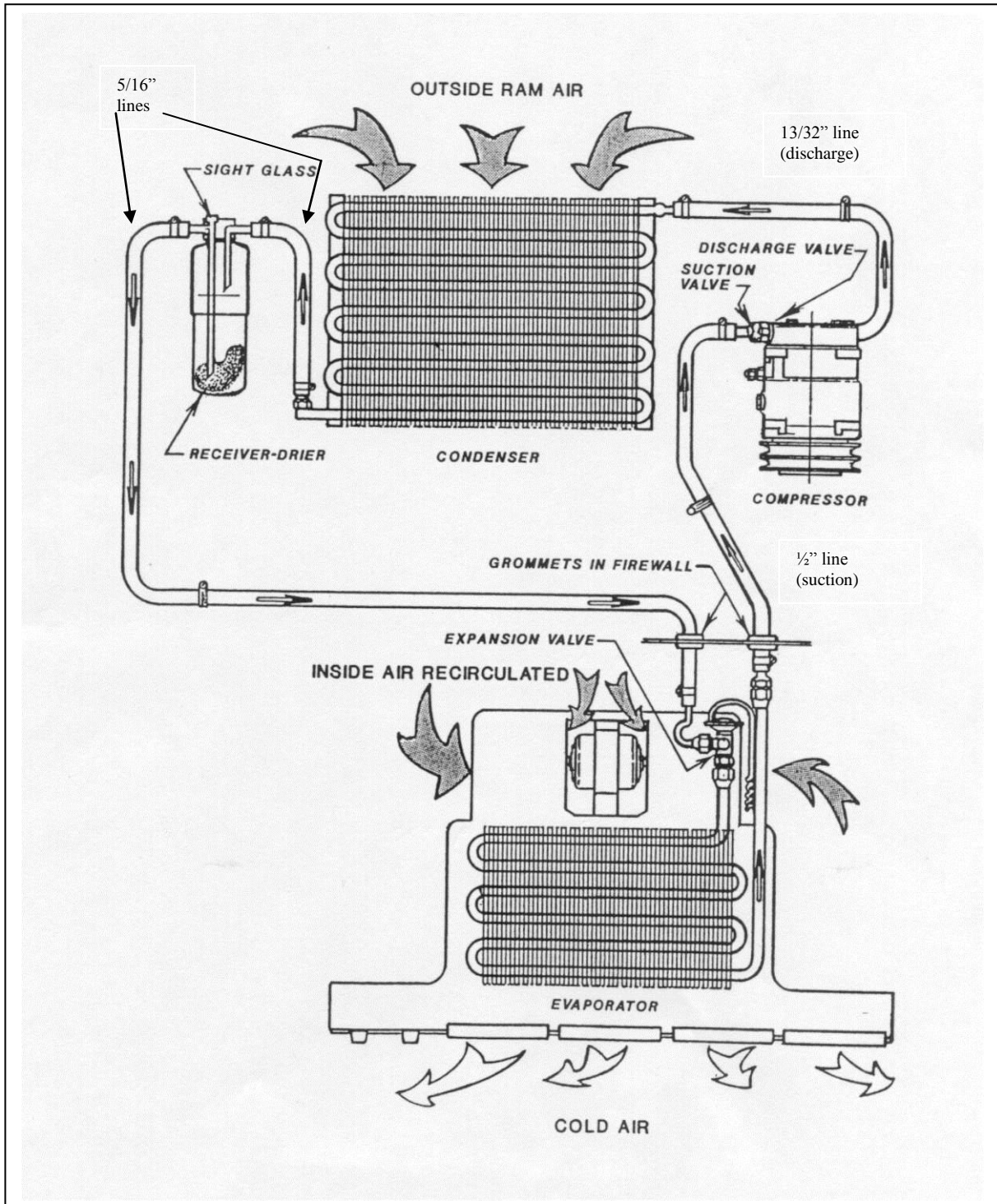

Thermostat Setting Procedures

- 1) Thermostat types
 - a) preset
 - b) adjustable
 - a) A preset thermostat is adjusted to its specific cut in and cut out temperatures when manufactured and does not have a rotary adjustment for the operator.
 - b) An adjustable or rotary thermostat has been manufactured to a predetermined cut in and cut out temperatures, but it is also operator adjustable to achieve the desired comfort level.

Both types of thermostats can have their factory settings adjusted by turning the setting screws on the body of the thermostat. One body type has the setting screws mounted externally and labeled for direction of rotation. The other body type requires the removal of the plastic end plate to expose the set screw.

- 2) Thermostat probe location: The location of the thermostat probe in an evaporator coil can be very important to achieve the maximum cooling potential of the coil while also preventing coil freeze-up. There is no set location for the thermostat probe to be put that will be optimum for all systems, but several rules of thumb may be followed:
 - a) Insert the probe in the coldest area of the evaporator coil.
 - b) Insert the probe from the top of the coil down, if possible.
 - c) Make sure that at least the last 3" of the thermostat probe are in the coil.

To find the most likely area where the coil is the coldest, consider these factors:

- 1) Direction of air flow through the coil.
 - 2) The coil area likely to have the lowest air flow.
 - 3) The inlet locations of the refrigerant into the coil.
 - 4) The inlet of the hotter outside air into the coil area.
-
- 1) Usually the coldest side of the evaporator coil will be the air outlet side. Often the thermostat probe can be inserted between the last and second last row of tubes.
 - 2) The lower air flow area of the evaporator coil in most systems tends to be near either end of the coil. These areas will be colder
 - 3) The area of the coil that the refrigerant inlet tube(s) occupy should be the coldest part of the coil.
 - 4) If the system is equipped with an outside air intake, where and how that air is brought into the evaporator area can have a large effect on the coil temperature. If all the outside air is piped into the evaporator in one area, that area will be considerably warmer in hot weather.

By looking at all these different factors, the area of an evaporator coil most likely to be the coldest can be determined.

Once the probe is inserted, the A/C system needs to be tested. Run the system to ensure that the thermostat is cycling the compressor off at the appropriate temperature. A core temperature ranging between 25° and 30° F should cause the thermostat to cycle off. The air temperature at the vent outlet closest to the evaporator coil should be between 38° F and 45° F when the compressor cycles off.

If the thermostat doesn't cycle off after a reasonable cool down period, and the air outlet temperature has dropped below 40° F, the cut in and cut out settings should be adjusted until the compressor is cycling on and off regularly. Let the system run for a decent time period (at least 15 min) and then check the evaporator coil for any signs of freezing.

Aeroquip E-Z Clip Assembly Instructions

Step 1. Cut the hose to proper length with an appropriate cutting tool. Aeroquip's hand held hose cutter has been specially designed for cutting all non-wire reinforced hose, such as GH-134 Multi-Refrigerant hose. Be sure the cut is made square to the hose length.

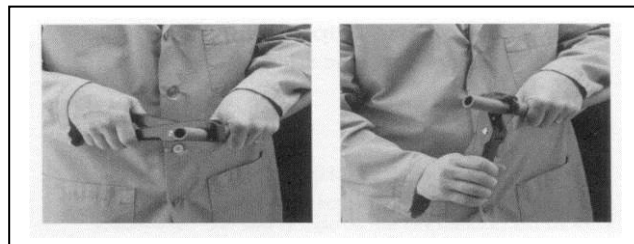

Step 2. Install two proper-sized clips onto the cut end of the hose. Orientation of the clips does not affect the performance of the connection. However, for ease of assembly, both clips should have the same orientation. NOTE: Failure to slide the clips over the hose at this time will require the clips to be stretched over the hose or fitting later. This may permanently damage the clip.

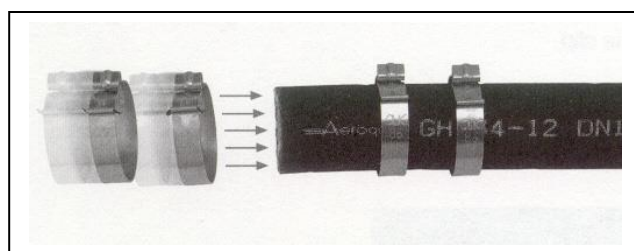

Step 3. Lubricate the nipple with a generous amount of the refrigeration or A/C system's compressor lubricating oil. This MUST be done to lower the force of nipple insertion.

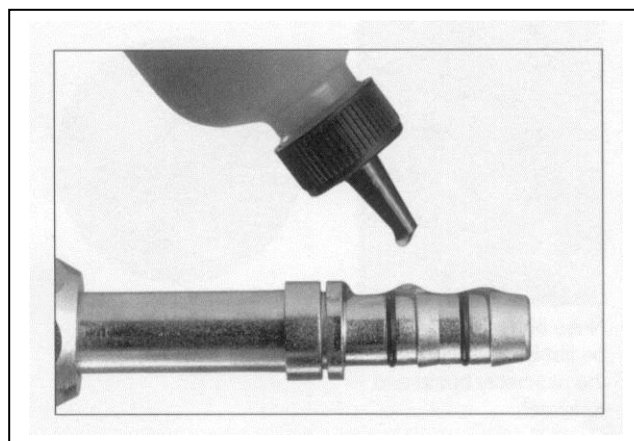

Step 4. Insert the nipple into the hose. To ensure that the nipple is fully inserted, check the gap between the cut end of the hose and the shoulder on the nipple. Care should be taken to avoid kinking or other damage to the hose during nipple insertion. NOTE: Be sure to wipe excess oil from the nipple and hose.



Step 5. Snap the cage into the groove on the nipple. The arms should extend over the hose length. When the cage has been correctly installed in the cage groove, the cage will be able to rotate in the groove.

This step **MUST** be performed to ensure:

1. The clips will be located over the O-rings on the nipple.
2. The connection will be compatible with the connection's pressure rating.

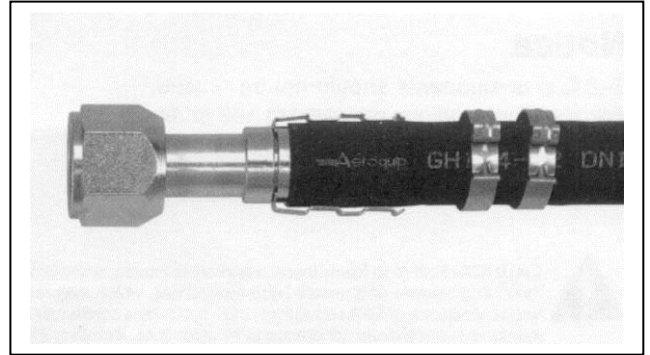

Step 6. Slide the clips over the cage arms and into the channels on each arm.

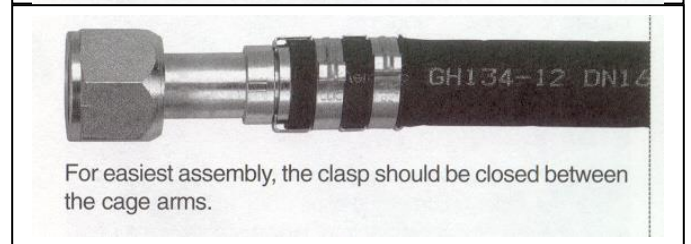

Step 7. Use the pliers to close the clips. The pliers should be positioned squarely on the clip connection points and should remain square during the closing of the clip.

NOTICE: E-Z Clip components should not be reused.

